



བགྲིས་བཅ་དོན་བརྒྱད་འབྲེལ་ཚད་འཛིན།

Tashi InfoComm Limited

TASHI INFOCOMM LIMITED

BIDDING DOCUMENT FOR SUPPLY OF

“Fiber Cables, Accessories & Other Equipment_2022”

Reference No: TICL/PRO-08/2022/ 287

Date: 06 / 05 / 2022





བགྲིས་བརྗོད་ཐོན་བསྐྱུད་འབྲེལ་ཚད་འཛིན།།

Tashi InfoComm Limited

**SECTION-I
INVITATION OF BIDS FOR SUPPLY OF**

“Fiber Cables, Accessories & Other Equipment_2022”

1. Tashi InfoComm Limited hereinafter referred to as “Purchaser” invites sealed bids from eligible Bidders for the supply of Fiber Cables, Accessories, and Other Equipment for FY-2022.
2. Interested eligible bidder(s) may obtain further information on the bid form directly from our website- www.tashicell.com or Procurement & Inventory Section, Norzin Lam, Post Box No. 1502, Thimphu, Bhutan. Contact Procurement & Inventory Section at the given contact details during office hours Only.
3. The Purchaser shall not be responsible for any costs or expenses incurred by the Bidder(s) in connection with the preparation or delivery of Bids.
4. Due to the current ongoing pandemic, all Bidders/Representatives of the Bidders may choose not to be present during the Opening of the Bidding Documents.
5. All correspondences with regard to the Bidding Documents shall be made in writing or email to the following address. Telephone enquires shall not be accepted.

Address for communication/contact.

Manager,
Procurement & Inventory Section,
Tashi InfoComm Limited,
Norzin Lam, Post Box No-1502,
Thimphu, Bhutan.
Email: procurement@tashicell.com; manager.procurement@tashicell.com;





བགྲིས་བཅད་དོན་བརྒྱུད་འབྲེལ་ཚད་འཛིན།།

Tashi InfoComm Limited

SECTION-II

INSTRUCTION TO BIDDERS

A. GENERAL

1. Scope of Bid:

- 1.1. The scope of the Bid shall be the supply of Fiber Cables, Accessories & Other Equipment FY-2022.
- 1.2. All the Bids are to be completed and submitted to the Purchaser in accordance with the Instruction to Bidders.

2. Eligibility:

- 2.1. The invitation for Bid is open to all the interested licensed national and global suppliers unless otherwise has been blacklisted by the Purchaser; RGoB and any other legal entities.

3. Cost of Bidding:

- 3.1. The Bidder(s) shall bear all costs associated with the preparation and delivery of its Bids, and the Purchaser shall in no case be responsible or liable for those costs.

4. Bidding Documents:

- 4.1. The Goods/Services required; Bidding procedures and terms & conditions are prescribed in the Bidding Documents. In addition to the Invitation for Bids, the Bidding Document includes:
 - a) Instructions to Bidders
 - b) General Terms & Conditions
 - c) Detail list of Goods/ and or Services to be supplied along with detailed specifications.
- 4.2. The Bidder(s) are expected to examine the Bidding Document, including all Instructions, Forms, Terms, and Specifications. Failure to furnish all information required by the Bidding Document or submission of a Bid not substantially responsive to the Bidding Document in every respect will result in rejection of the Bid.

5. Bid Prices:

- 5.1. The Bidder(s) shall complete the appropriate Price Schedule included herein, stating unit prices, extended amount and the expected countries of origin of the Goods to be supplied, if applicable
- 5.2. Prices quoted by the Bidders shall remain fixed and valid for the period stated in **Section-II, Clause 6** of the Bidding Document, and will not be subject to variation on any account.
- 5.3. The bid Currency shall be Ngultrum (Nu) for this bidding document. Except for third country bidder(s), the bidder(s) from the rest of the countries are not allowed to quote in US dollars. The third country bidder(s) who quoted in US Dollar shall be converted into Ngultrum at the prevailing exchange rate (Selling TT rate of any financial institution) as on the date of tender opening for evaluation purposes.





བློ་སྒྲིལ་བཅའ་ཁྲིམས་ལྟར་བསྐྱོར་ཆེད་འཛིན།།

Tashi InfoComm Limited

5.4. Trade Terms shall be:

Unless otherwise stated, the following shall be the trade terms for this bidding document:

- a) For Local & Indian Bidder(s): CIF, TICTL Warehouse, Thimphu, Bhutan
- b) For Third Country Bidder: CIF, Kolkata, India.

6. Bid Validity:

- 6.1. The Bids shall be valid for 12 months from the date of Bid Submission.

7. Taxes/Duties & other levies:

- 7.1. Unless otherwise stated, the applicable taxes/duties/any other levy both within and outside Bhutan shall be under the scope of the Bidder.
- 7.2. The third country bidder(s) or bidder(s) from India may exclude applicable taxes/duties while submitting the bid. The applicable taxes including customs clearance shall be under the scope of the Purchaser. However, applicable taxes/duties, etc shall be factored in during the time of evaluation to determine the final landing cost.

8. Evaluation:

- 8.1. The purchaser shall evaluate the quotations based on specifications given in the bidding document to ascertain the lowest evaluated bidder(s).
- 8.2. The evaluation shall not only be based on the quoted rates but the specifications and complete datasheet of the Fiber Cables, Accessories, and Other Equipment against the purchaser's requirement. And previous working experience with the Purchaser shall also be factored in during the evaluation.
- 8.3. The Evaluation Team & Management Tender Committee's evaluation decision shall be final and binding, without thereby incurring any liability to the affected Bidder or Bidders or any obligation to inform and explain the affected Bidder or Bidders on the grounds of the evaluation team & Management Tender Committee's evaluation decisions and reports.
- 8.4. The lowest quoted unit rates alone do not guarantee the award of the contract/purchase order.
- 8.5. The evaluation shall be based on the respective line-item basis. The bid shall not be considered as a "single package".

9. Award of Purchase Order/Contract:

- 9.1. The Purchaser shall award the PO or supply contract to the Lowest Evaluated bidder(s) for the respective line-item(s).





བགྲིས་བཅད་དོན་བརྒྱུད་འབྲེལ་ཚད་འཛིན།།

Tashi InfoComm Limited

10. Delivery:

10.1. Delivery should be completed as per the given schedule:

- a) Within 45-60 days from the date of confirmed PO depending on the nature of the items(s) awarded to the respective successful bidder(s).
- b) The detailed terms & conditions shall be mentioned in the confirmed Purchase Order/Supply Contract.

10.2. The purchaser (TICL) may provide a delivery time extension beyond the actual delivery date taking into account the actual need-by-day and project schedule of TICL. However, subject to the approval of the Management Tender Committee and may levy the Liquidity Damaged (LD) Penalty.

10.3. The Time Extension request/provided may not exceed 15 days at the maximum OR depend on the approval granted by the Management Tender Committee of the purchaser. The supplier has to send an email/in writing requesting a time extension with genuine reasons (along with supporting documentation).

11. Inspection of Goods:

11.1. The goods are subject to Physical Inspection upon delivery at TICL Warehouse and testing & commissioning in due course of time. The Goods found to be faulty, DOA, and not meeting specifications/requirements of TICL after the final inspection, installation, and testing shall be rejected at the cost of the bidder.

11.2. The goods that are found to be DOA, faulty, etc shall be informed to the respective supplier(s) and it has to be replaced as per the terms & conditions that will be specified on the rejection notice.

12. Warranty (If applicable):

12.1. The Warranty shall be a minimum of 12 months from the date of delivery OR standard manufacturer's warranty, whichever is longer.

13. Payment:

13.1. The Payment shall be made 100% against delivery within 7 working days from the date of receiving the Bill/Invoice.

13.2. Advance payment up to a maximum of 30% of the total PO value may be released at Purchaser's discretion against furnishing an equivalent amount of bank guarantee for the advance payment valid 3-6 months beyond the delivery deadline.





བགྲིས་བརྒྱ་དོན་བརྒྱུད་འབྲེལ་ཚད་འཛིན།།

Tashi InfoComm Limited

14. TDS/FCT:

- 14.1. TDS (Tax Deduction at Source) and or FCT (Foreign Contract Tax) shall be deducted as per the existing Rules and Regulations of the Department of Revenue & Customs, Bhutan (wherever applicable).

15. EMD (Earnest Money Deposit):

- 15.1. The bidder should submit **not less than 2% of the total quoted value** as part of the EMD along with the quotation in the form of a Demand Draft or Bank Guarantee from any of the financial institutions located in Bhutan. The bidder(s) other than Bhutanese national can furnish EMD from the financial institutions in their respective countries OR any of the Bhutanese Financial Institutions. The EMD may be directly deposited into the Purchaser's bank account (please contact the purchase requesting bank details via email).
- 15.2. The bidder(s) failing to submit the EMD as per the requirement shall result in the rejection/cancellation of their bid.
- 15.3. The EMD shall be valid for 30 days beyond the submission deadline of the bidding document. The EMD should be drawn in favor of **"Tashi InfoComm Ltd., Norzin Lam, Thimphu, Bhutan"**.
- 15.4. EMD of unsuccessful bidder(s) shall be returned promptly after the finalization of the quotation.
- 15.5. EMD shall be forfeited if:
a) A bidder withdraws its bids before the finalization of the bids in every respect.
b) The successful bidder fails to submit Performance Security as per the terms specified in the bidding document.
- 15.6. EMD of the successful bidder shall be returned promptly upon submission of Performance Security.

16. Performance Security:

- 16.1. The successful bidder should submit not less than 10% of the total PO/contract value as Performance Security within 1 week from the date of PO/signing of the supply contract.
- 16.2. Performance Security shall be drawn in favor of **"Tashi InfoComm Ltd, Thimphu"** in the form of a Demand Draft or Bank Guarantee or can be deposited directly into the purchaser's bank account(contact purchaser via email requesting bank details).
- 16.3. Performance Security shall be valid for the period of **1 YEAR** from the date of Purchase Order/Supply Contract.





བགྲིས་བཅད་དོན་བརྒྱད་འབྲེལ་ཚད་འཛིན།།

Tashi InfoComm Limited

- 18.2. Should the selected Bidder(s) fails to supply the full order quantity within the given deadline, the purchaser reserves the right to cancel the quantities not supplied and place an order to the Second Lowest Evaluated Bidder or otherwise take necessary decision deemed fit by the purchaser.

In such a case, the Purchaser shall recover as part of Liquidated Damages, the difference amount between the purchase order rate and the actual rate paid to the second-lowest evaluated bidder for the quantities not supplied. The amounts shall be either adjusted from the Performance Security or bill/invoice amount of the supplied quantity.

19. Force majeure:

- 19.1. Force Majeure shall mean such unforeseeable occurrences beyond the control of the Purchaser and Bidder which occur after the date of issuance of Purchase Order or signing of Supply Contract and which were not reasonably foreseeable at the time of issuance of Purchase Order or signing of Supply Contract and which effects are not capable of being overcome without the unreasonable expense and/or loss of time to the Purchaser and the Bidder concerned, including, provided that the aforementioned conditions are met, but not limited to:
- Natural catastrophes, earthquakes
 - Strikes and blockages
 - War or war-like conditions, mobilizations, revolutions or riots, the act of Public enemy, sabotage, terrorism.
 - Restriction by actions, omissions, or interventions from Public Authorities (including but not limited to changes in laws, regulations or import/export, security restrictions).
 - The Party who wishes to plead Force Majeure shall inform the other party of the First party's perception of the effects of such force majeure on the fulfillment of the issued purchase order/signed Supply Contract. Should any event of force majeure cause an increase in the time required for the performance of any part of the purchase order/signed Supply Contract, an equivalent adjustment shall be made in the time required for performance.

However, if the force majeure situation continues for more than two months, the purchaser and bidder shall decide whether the contract should be terminated.

20. Termination:

- 20.1. In the event of any failure by the Bidder to perform any of its obligations under the issued purchase order or signed Supply Contract or upon unsatisfactory performance, the purchaser shall terminate the purchase order or signed Supply Contract by giving a prior written notice of Fifteen (15) days, without any obligation to the Bidder. However, the purchaser shall pay the actual due amount for the quantity supplied and accepted by the Purchaser to Bidder on termination of the issued purchase order or signed Supply Contract.





བཀྲིས་བཅད་དོན་བརྒྱད་འབྲེལ་ཚད་འཛིན།།

Tashi InfoComm Limited

21. Indemnity:

21.1. The bidder(s) shall comply with all the laws in force in Bhutan and outside. The laws will include all national, provincial, municipal, or other laws that affect the performance of the issued purchase orders or signed Supply Contract and bind upon the Bidder(s). The Bidder(s) shall indemnify and hold harmless the Purchaser for and against any and all liabilities, damages, claims, fines, penalties, and expenses of whatever nature arising or resulting from the violation of such laws by the Bidder(s).

22. Dispute Settlement:

22.1. If any dispute should arise in connection to the issued purchase order or signed Supply Contract, the Parties shall try to settle any such dispute through good faith and negotiations including escalation to senior Management where each party deems it appropriate. If negotiations fail, the matter shall be referred to the Court of Law.

23. Governing Law and Jurisdiction:

23.1. The terms and conditions in this Bidding Document or issued Purchase Order or signed Supply Contract shall be read and construed in accordance with the laws of the Kingdom of Bhutan and the District Court of Thimphu, Bhutan shall have jurisdiction over any disputes arising out of the Contract.

(Handwritten signature)





བགྲིས་བཅད་དོན་བརྒྱན་འབྲེལ་ཚད་འཛིན།།

Tashi InfoComm Limited

SECTION-III
GENERAL TERMS & CONDITIONS:

In this Bidding Document, the following terms shall be interpreted as indicated below:

“The Bid” means the proposal submitted by the Bidder

“The Purchaser” means the organization purchasing the Goods. In this case, M/s. Tashi InfoComm Limited (TICL).

“Day” means a calendar day. Any other terms shall be interpreted as per the TICL Procurement Manual, 2009.

1. **Bid Submission:** The Bids should be submitted in a sealed envelope (Single Envelope Method- **copy not required**) addressed to “**Manager, Procurement & Inventory Section, TICL** against Reference No. TICL/PRO-09/2022/287 dated 06/05/2022”.
2. **Bid Submission:** 11:00 Am (Bhutan Standard Time); 25/05/2022
3. **Bid Opening Time:** 2:00 pm : 25/05/2022 at TICL conference hall. Interested Bidder(s) may attend the bid opening on the given deadline and place.
4. Bidding Documents received after the deadline (time & date of submission) shall not be accepted and opened during the bid opening. The quotations shall automatically stand as “Rejected”.
5. The Purchaser shall not be responsible for any damages, losses, breakages, or shortages of any items while in transit for delivery of Goods to the TICL Store/warehouse.
6. The Bidder should enclose a Xerox copy of a valid Trade License, Tax clearance, Power of Attorney, and other relevant documents.
7. **Clarification on Bidding Document:** The bidder(s) are expected to examine the Terms and Conditions stated in the Bidding Document, Bill of Materials, Specifications, Drawings, etc furnished along with the Bidding Document. Once the bids are submitted by the bidder(s), It shall mean:
 - a) The bidder(s) have examined, read, and accepted all the terms and conditions stated in the Bidding Document, the specifications of the goods/services, Drawings/Designs, etc furnished in the Bidding Document. Thereafter, no grievance, complaints, etc (whatsoever nature may be) shall be accepted.
 - b) The bidder(s) can seek clarification (through email/in writing) with regard to the terms & conditions of the Bidding Document, the specifications of the goods/services, Drawings/Designs, etc furnished in the Bidding Document before the submission of the Bids.

(Handwritten signature)





བཀྲིས་བཅད་དོན་བརྒྱད་འབྲེལ་ཚད་འཛིན།།

Tashi InfoComm Limited

- c) Clarification can be sought through email or in writing to any of the given officials during office hours. Email ID: manager.procurement@tashicell.com OR procurement.finance@tashicell.com OR procurement@tashicell.com. Address: Manager, Procurement & Inventory Section, Tashi InfoComm Ltd., Norzin Lam, Post Box No. 1502, Thimphu, Bhutan.
8. The Bids not substantially responsive to the Bidding Document in every respect will result in rejection of the Bids.
9. For any complaints or grievances, the bidder(s) may write directly to the Management Tender Committee of the Purchaser through email. The Email ID is procurement@tashicell.com.
10. Product samples and catalog/brochures containing details of technical and functional specifications shall be submitted along with the Bids wherever applicable. Failing which, shall result in rejection of the Bidding Document.
11. The decision of the Corporate/Management Tender Committee shall be final and binding.





བཀྲིས་བཅད་དོན་བརྒྱད་འབྲེལ་ཚད་འཛིན།།

Tashi InfoComm Limited

SECTION-IV

The complete **Bill of Materials (BOM)** is as stated in **Appendix I**. The Bids should be submitted in the below format in your company Quotation Form.

Appendix-I:

S/L	Description	UoM	Qty	Unit Rate	Amount
1.	1. Detail as given in Appendix-I				

Total

Note:

1. Please attached details of the technical and functional specifications along with the Bidding Document. Failing to do so, will result in the rejection of your bidding document.
2. Mention the Country of origin of goods in the bidding document.
3. Wherever required, samples are to be submitted as mentioned in the "remarks" of the BOM.



Appendix-i: BOM_Price Schedule

S/L	Description	UoM	Qty	Unit Rate	Amount	Remark
1	FC/UPC to SC/UPC Patch cords, G652D, Single mode, 2mm dia. Duplex 5 meter, outer jacket LSZH, Blue colour	Nos	200			1 pcs Sample Requ
2	SC/UPC to SC/UPC Patch cords, G652D, Single mode, 2mm dia. Duplex 5 meter, outer jacket LSZH, Blue colour	Nos	200			
3	Wedge type tension clamp, suitable Cable Diameter Range (mm):4~8, Breaking Load (KN): 5	Sets	500			1 pcs Sample Requ
4	Pole Clamp Set: Hoop Fasten Retractor, material: cold galvanizing; fixed on the pole by steel hoop, used together with S-type suspension clamp to fix the cable	Sets	500			1 pcs Sample Requ
5	Fiber Cable Clamp Set: Materials-Stainless steel. Width-12mm• Thickness-2mm• Length-700mm	Sets	500			
6	Kevlar scissor	Nos	5			
7	TZE tape, 9mm(0.35mm) yellow, white, pink etc.	Nos	10			
8	pvc coated flexible outdoor steel cable conduit tube hose pipes	Nos	20			
9	Lithium battery for Walkie-Talkie	Nos	3			
10	HDPE Pipe(32mm) 8PN roll (100m), Bhutan Polythene/Equivalent	Roll	20			
11	HDPE Pipe(25mm) 8PN roll (100m), Bhutan Polythene/Equivalent	Roll	5			
12	All-Weather Fiber to the Home Tent Pelsue Fiber Splicing Tents	Nos	2			
13	Splicing Foldable Table	Nos	1			
14	Head Light	Nos	5			
15	19" Sliding type FODP-48 ports, SC Duplex adapter with loaded pigtail -1 meter, colour of 12	Nos	50			1 pcs Sample Requ
16	CPRI Cable (20mm) (armoured, Multimode), IP67 protection,	Nos	20			
17	Optical Transceiver(SFP+,850nm,10Gb/s,-7.3~-1dBm,-9.9dBm,LC, MM,0.3km)	Pairs	20			1 pcs Sample Requ
18	10G BIDI SFP+ transceiver modules(10 Gbps, 2km,SM, Output Power(-3 to-2dBm), LC, 1330/1550nm	Pairs	10			
19	10G BIDI SFP+ transceiver modules(10 Gbps, 20km,SM, Output Power(-3 to-2dBm), LC, 1330/1550nm	Pairs	25			
20	10G BIDI SFP+ transceiver modules(10 Gbps, 40km,SM, Output Power(0 to 5 dBm), LC, 1330/1550nm	Pairs	10			
21	Optical functional module,1000BASE-T -SFP RJ45Electrical Module,Auto Negotiate,100m ,-40~85	Pairs	40			
22	Optical Transceiver,eSFP,1310nm,155M~2.67G,-10~-3dBm,-18dBm,LC,SM,20km	Pairs	20			
23	1.25Gbps SFP BIDI Transceiver Module (Single-mode, 20km, LC,1310nm/1550nm)	Pairs	30			
24	1.25Gbps SFP BIDI Transceiver Module (Single-mode, 40km, LC,1310nm/1550nm)	Pairs	10			
25	1.25Gbps SFP BIDI Transceiver Module (Single-mode, 80km, LC,1310nm/1550nm)	Pairs	10			
26	Fiber Optic Drop cable , 6cores Single mode, G652D with aramid yarn & self-supporting for the span of 100 meters, dielectric	km	15			1 mtrs Sample Requ



27	Fiber Optic Drop cable, 12 Cores Single mode, G652D with aramid yarn & self-supporting for the span of 100 meters, dielectric	Km	15			1 mtrs Sample Req
28	GI Pipe OD 32mm, 6PN	Nos	20			
29	UG Fiber 48F (Single mode G652D with Glass yarn. Outer & Inner sheath thickness ≥ 2 mm provided with two rib cords in each sheath. OD-114.3 mm. Loose 4 tubes -1 tube-12cores.)	Km	10			1 mtrs Sample Req
30	ADSS Fiber 24F (ADSS fiber cable, 24F, Single mode G652D, FRP ROD, Aramid yarn-12.6kg/km, Loose tube 4, UV Resistant(Black) Polythene HDPE. Inner sheath thickness ≥ 1.2 mm, outer sheath thickness ≥ 2 mm, outer cable diameter 14.8 \pm 0.5mm, Cable weight 165 \pm 20 KG/km. Max allowable tension 13.0 KN. Crush Resistance 2000 Newton/100mm. Minimum bending radius 280 mm. Max operating temperature -30 \circ to+70 \circ . Attenuation @1310nm (dB/km) ≤ 0.36 . Attenuation @1550nm (dB/km) ≤ 0.23 . Double Rib Cords in both sheath)	Km	30			1 mtrs Sample Rec
31	ADSS Accessories (set) for 90mm pole (Span length-100 meter. Cable diameter from 14.3 to 15.3 mm. Max. tensile strength ≥ 13 KN/Pole clamp, Helix, vibration damper, Chain-link, down lead clamp)	Sets	200			1 set Sample Requ
32	ADSS Accessories (set) for 110mm pole (Span length-100 meter. Cable diameter from 14.3 to 15.3 mm. Max. tensile strength ≥ 13 KN/Pole clamp, Helix, vibration damper, Chain-link, down lead clamp)	Sets	200			1 set Sample Requ
33	ADSS Cross Arm (90-150mm dia) Pole diameter range 90-150 mm, Hot Galvanization	Nos	100			1 set Sample Requ
34	ADSS Joint Enclosure. Dome Type (Joint closure-mechanical, 530 mm X 220mm, material ABS & PP, colour of tray- Off white/light grey, cable Entry ports 4 Nos. round & 1 no.oval. Cable entry sealing- Heat shrink sealing/Mechanical sealing. Dome & Base sealing-"C" calmp provisioned)	Nos	100			1 set Sample Requ
35	ADSS Armoured Fiber (12F) km(ADSS fiber cable, 12F, Single mode G652D, FRP ROD, Aramid yarn-10.kg/km, Loose tube 4, UV Resistant(Black) Polythene HDPE. Inner sheath thickness ≥ 1.2 mm, outer sheath thickness ≥ 2 mm, outer cable diameter 14.8 \pm 0.5mm, Cable weight 165 \pm 20 KG/km. Max allowable tension 13.0 KN. Crush Resistance 2000 Newton/100mm. Minimum bending radius 280 mm. Max operating temperature -30 \circ to+70 \circ . Attenuation @1310nm (dB/km) ≤ 0.36 . Attenuation @1550nm (dB/km) ≤ 0.23 . Double Rib Cords in both sheath.)	Km	5			1 mtrs Sample Rec
Total Amount in Nu						



Consumption of Stores

6. Kevlar Scissor, Miller KS-1 Yellow Fiber Optic Kevlar Scissors, Easily Portable Utility Scissors for Working Technicians, Electricians, and Installers, Heavy-Duty Cable Cutters, 5.5 Inches

Color	Yellow
Material	Alloy Steel
Brand	Miller
Blade Material	Alloy Steel
Item Dimensions LxWxH	5.5 x 8.88 x 0.63 inches



12. All-Weather Fiber to the Home Tent | Pelsue Fiber Splicing Tents

The **Pelsue** Fiber Splicing Tents are the solution we have been looking for when it comes to protecting your workers from the elements while on the job.

Each tent is built with durable, lightweight fabric and fiberglass rods so we can easily set up and tear down the tent with one man.

Our Fiber Splicing Tents incorporate vent sleeves and cable slots to allow for the pass through of splice cases and ventilation, so we can work comfortable and stay focused on the task.



K *Smith*

Model	Nominal Size	Weight	Folded Dimensions
6705	6' W x 6' L x 7' H	17 lbs.	7" D x 4.6' H
Fabric	Frame	Construction	
200 denier polyester (top)	Cast aluminum hubs	Double stitched binding	
250 denier polyester (sides)	Pultruded fiberglass rods	Exposed roof seams sealed	
Urethane coated		Non-metallic snaps & rings	
Waterproof			
Mildew resistant			
UV protected			
Flame retardant (to CPAI-84 & NFPA701)			

14. Head Light, 1000 lumens xml t6 adjustable zoomable led headlight, bike hunting headlamp, rechargeable camping headlamp



[Handwritten signature]

[Handwritten signature]

13. Splicing Foldable Table (CT27 CableTable Fiber Optic Work Table and Tripod)



Description: CT27 Napco CableTable Fiber Optic Work Table and Tripod
Item #: CT27
Weight: 18 lbs.

[Handwritten signature]

Consumption of Stores

8. Flexible Pipe



Length of Pipe	30 m
Usage/Application	Industrial
Weight	2 kg
Size	12mm to 100mm
Type	Nos

9. Lithium Battery for Walkie-Talkie (MOTOROLA SMP818 LB-75L 2200mAh Li-Ion Battery)



Compatible With

- Motorola Smp818

Functional Description

- Voltage: 7.4v
- Capacity: 2200 Mah
- Chemistry: Li-ion

Package Included

- 1 * Motorola Smp818 Lb-75l

Handwritten signature

Drop Optical Fiber cable

26 & 27

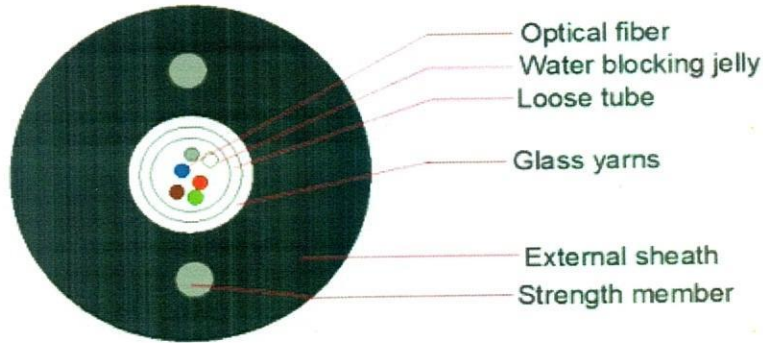

Optical Fiber Characteristics (ITU-T G.652D).

Parameters	Speciation	
	Before Cable	After Cable
Fiber Type	SM G652D Fiber	
Mode Field Diameter (um)	9.2±0.4 (@1310nm)	
Cladding Diameter (um)	125±0.7	
Coating Diameter (um)	245±10	
Core Concentricity Error (um)	≤ 0.6	

Fiber attenuation (dB/Km)	@1310nm	≤ 0.35
	@1550nm	≤ 0.21
Macro Bending Loss (dB)	30mm radius, 100turns	≤ 0.05 @1550nm

Fiber Cable Specifications













Parameters		Specifications
Fiber Count		2~12
Loose Tube	Materials	PBT
	Diameter	2.0
	Fiber/tube	2~12
	Filling compound	Fiber jelly
Strength member	Material	FRP
	Diameter (mm)	0.8
	Number	2

[Handwritten signatures]

Drop Optical Fiber cable

Additional strength member	Material	HDPE
Jacket	Colour	Black
	Nominal Thickness (mm)	1.8
Approx. Cable Diameter (± 0.5)		6.2
Cable weight Approx. (kg/Km)		33
Tensile Strength (N)	Long Term	2000
	Short Term	1000
Crush Resistance (N/100mm)	Short Term	2000
Bending Radius (mm)	Dynamic	20D
	Static	10D
Cable Attenuation (dB/Km)	@1310	≤ 0.36
	@1550	≤ 22
Package (Km/drum)		2
Operating Temp ($^{\circ}\text{C}$)		-10~ + 45

Fiber Colours

Fiber counts	1	2	3	4	5	6	7	8	9	10	11	12
Colour												

EM

JK

32. Specifications for ADSS fixing accessories

a. ADSS joint Enclosure

SI No.	Description	Specification
1.	Product name	JOINT CLOSURE-MECHANICAL
2.	Dimensions (H x D)	530 mm X 220 mm
3.	Material	ABS & PP
4.	Colours of tray	Off white/light grey
5.	Cable Entry Ports	4 No's round & 1 no's oval
6.	Cable Entry Sealing	Heat shrink sealing/ Mechanical sealing
7.	Dome & Base Sealing	"C" clamp provisioned

b. Two way Tension

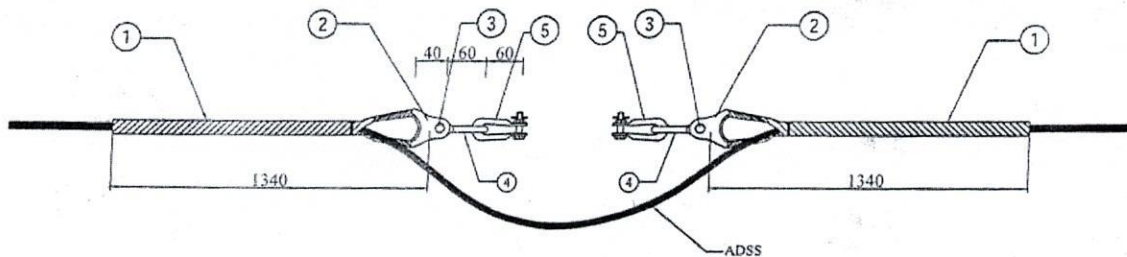

5	2	Bow shackle	U-4	Forged Steel
4	2	Extension Link	ZH-4	Forget Steel
3	2	Bolt	M12*50	Forget Steel
2	2	Clevis Thimble	UXL-40	Steel or Ductile iron
1	2	Reinforcing rod	SAT015155	Al clad steel
Item	Qty.	Description	Type	Material

Note:

1. Span length = 100 M
2. To ensure diameter of cable from 14.3 to 15.3 mm
3. Max. tensile strength \geq 13KN

[Handwritten signatures]

c. Pole clamp for tension (Telescopic)

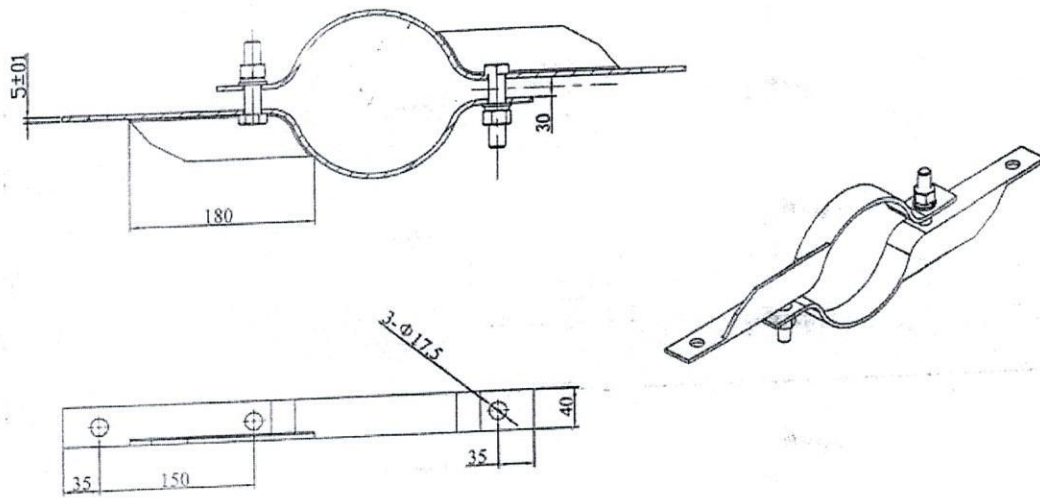

Note:

1. Pole diameter range, $\phi = 100 - 130$ mm
2. Hot-galvanization.

d. Suspension

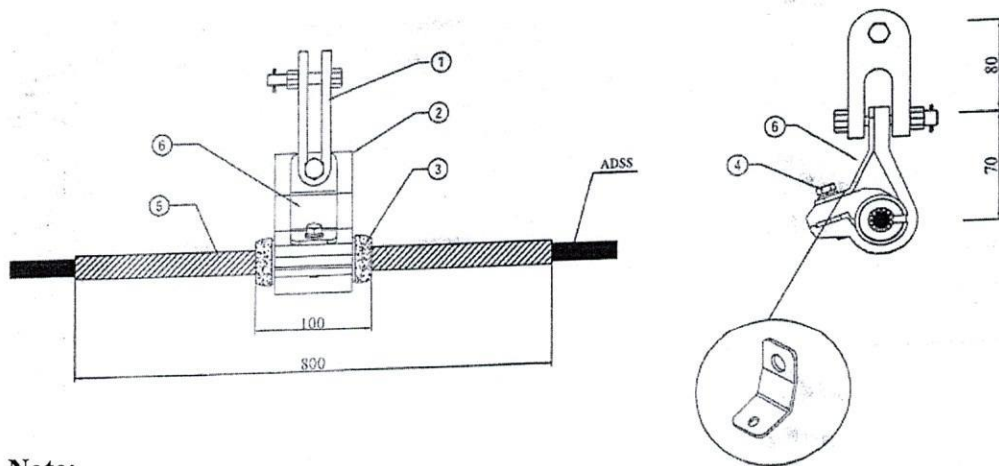

Note:

1. Span length = 100 M
2. To ensure diameter of cable from 14.3 to 15.3 mm
3. Max. tensile strength ≥ 13 KN

Handwritten signatures and initials in blue ink.

e. Suspension clamp (Telescopic)

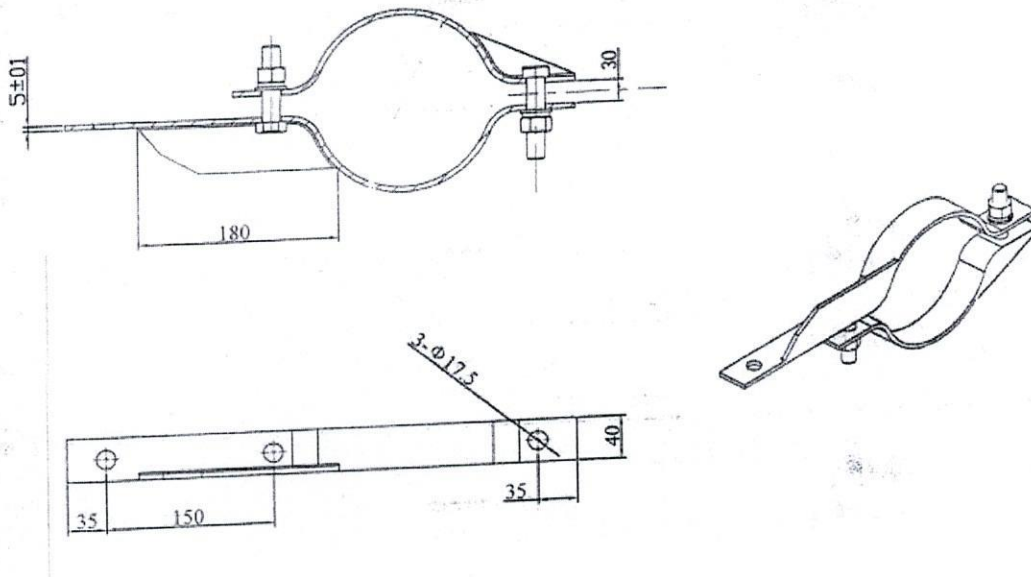

Note:

1. Pole diameter, $\phi = 100-130$ mm
2. Hot-galvanization

f. Cross Arm

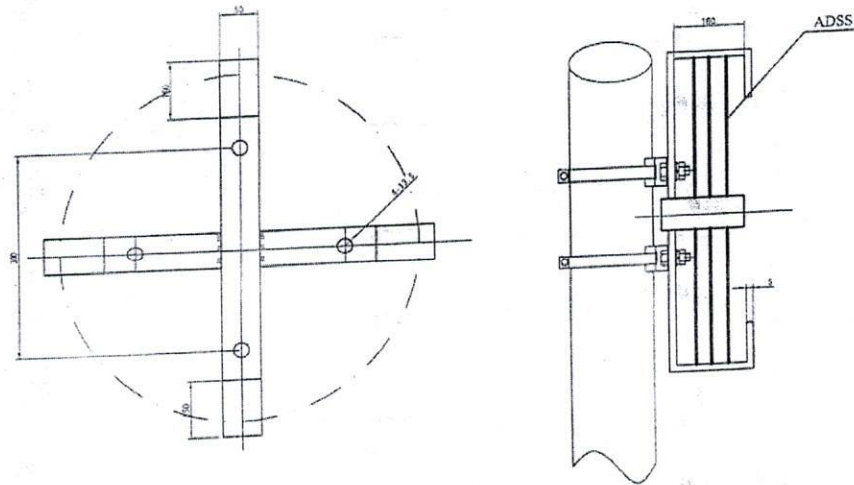

Note:

1. Pole diameter range $\phi = 100-130$ mm
2. Hot-galvanization

[Handwritten signature]

[Handwritten signature]

g. Down lead clamp

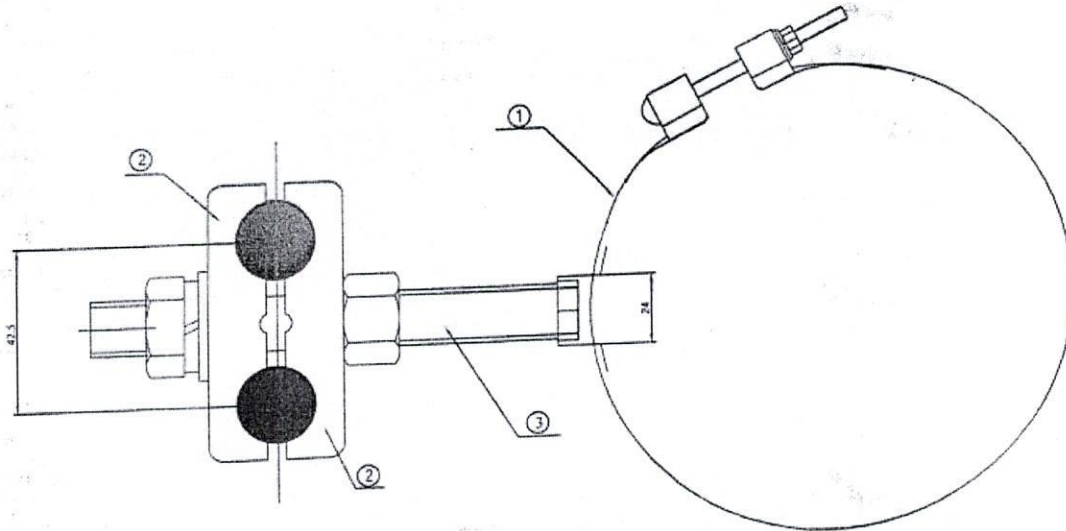

Note:

1. Pole diameter range $\phi = 100- 130$ mm
2. To ensure diameter of cable from 14.3 to 15.3 mm

3	1	Bolt	M12*70	Galv. steel
2	2	Rubber clamp	/	Rubber
1	1	Hoop cleat	/	Stainless steel
Item	Qty.	Description	Type	Material

h. Corona coil

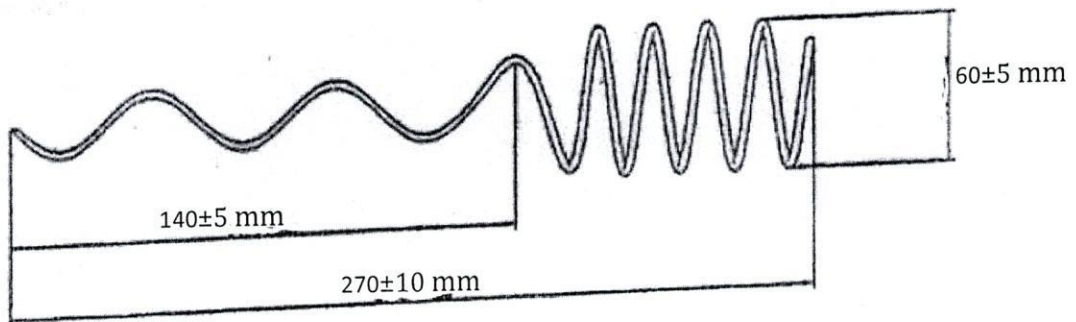

[Handwritten signature]

Note:

1. Material: Aluminium alloy
2. To ensure diameter of cable from 14.3 to 15.3 mm
3. Wire diameter: 6 ± 0.3 mm

